



move faster and be stronger  
schneller und stärker sein

# dkPOWER PRESS

---

---

---

---



dkPOWER PRESSES work far more economically than conventionally driven presses. That's because our range of presses has the advantage of dkPOWER hydropneumatic cylinders.

dkPOWER presleri konvensiyonel tahrikli diğer preslerden daha ekonomik çalışırlar. Çünkü pres yelpazemiz dkPOWER hidropnömatik silindirlerinin avantajlarını içinde bulundurur.

# dkPOWER PRESS

## hydropneumatic presses hidropnömatik presleri



dkPOWER PRESS hydropneumatic presses are operated only by compressed air, activating the hydraulic power stroke automatically. They complete the advantage of pneumatic and hydraulic presses.

dkPOWER PRESS hidropnömatik presleri basınçlı hava ile kumanda edilir ve hidrolik iş stroğuna otomatik olarak geçer. Pnömatik ve hidrolik preslerin avantajlarını biraraya getirir.

During the pneumatically operated rapid stroke the workpiece is approached in rapidly at low power. The hydraulic power stroke commences automatically as soon as resistance is met. Thus especially with these models the input energy is used most economically.

Pnömatik hızlı hareketi boyunca, düşük güçte hızlı olarak iş parçasına yaklaşılır. İş stroğ bir direnç ile karşılaştığında otomatik olarak devreye girer. Bu özellik sayesinde giriş enerjisi mümkün olduğu kadar ekonomik kullanılır.



**Forming**  
Form verme



**Punching**  
Delme



**Riveting**  
Perçinleme



**Bending**  
Bükme



**Pressing**  
Presleme



**Squeezing**  
Sıkıştırma



**Marking**  
Markalama



**Joining**  
Kenetleme

High-tech power for all forming applications from 0,6-100 tons. 0,6-100 ton'a kadar bütün form verme operasyonlarında yüksek teknoloji.

dkPOWER PRESSES can be used to perform the most varied forming tasks in economical way.

dkPOWER presleri çeşitli form verme uygulamaları için en ekonomik çözüm olarak kullanılabilir.

# dkPOWER PRESS

## hydropneumatic presses hidropnömatik presleri

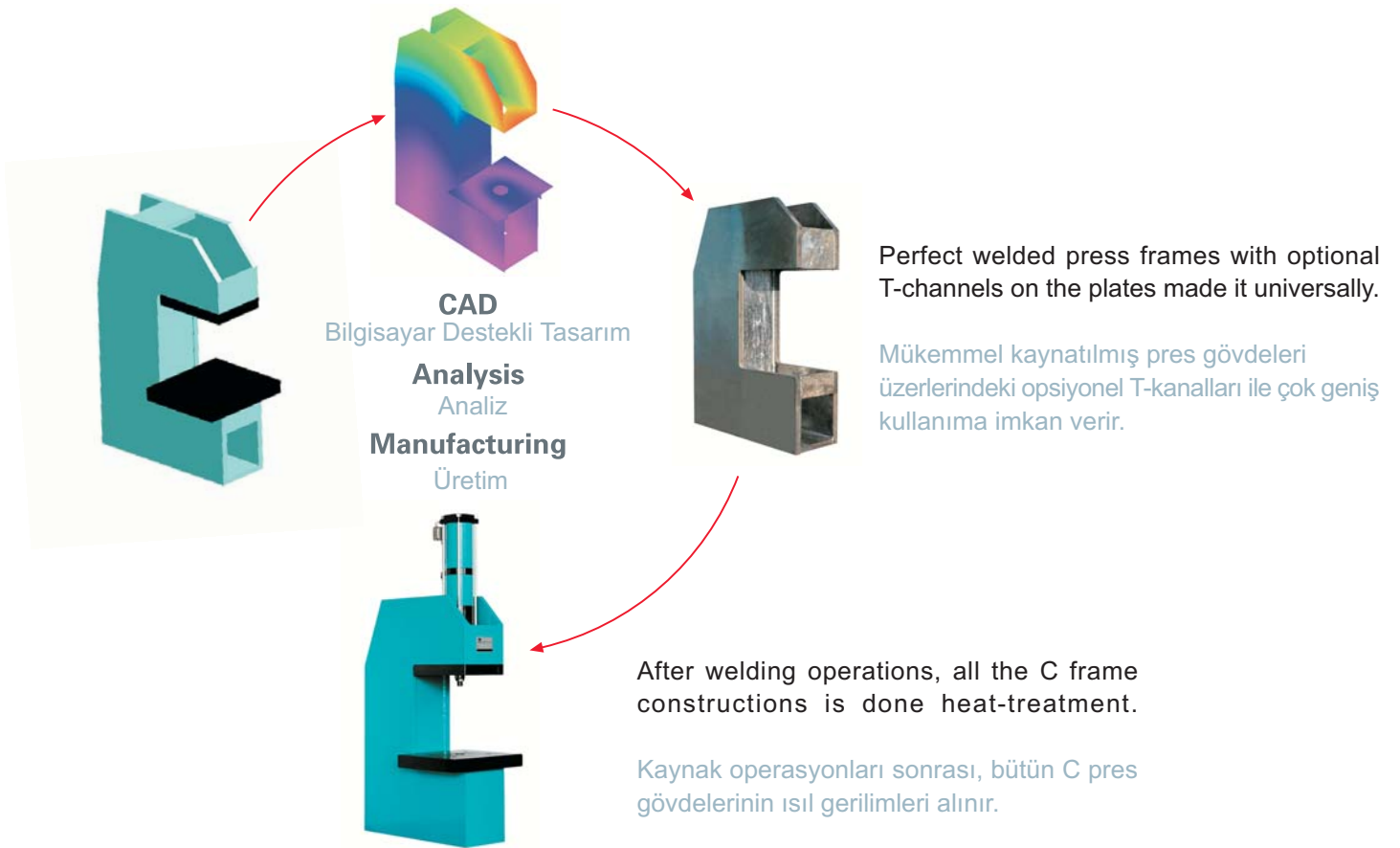

### dkPOWER PRESS manufacturing process

- We design our products at 3D CAD program.
- We analysis our construction at MSC Nastran for WINDOWS program.(F.E.A.)
- We checked our design and improve our construction facilities.

Our manufacturing program is done according to the optimal design.

dkPOWER PRESS üretim programı

- Preslerimiz 3 boyutlu CAD programında dizayn edilir,
- MSC Nastran for windows programında Sonlu elemanlar yöntemi ile analiz edilir,
- Sonuçta dizayn kontrol edilir ve gerekiyorsa pres özellikleri iyileştirilir.

Üretim programımızdaki ürünler optimum dizayna göre imal edilmektedir.

Other presses consume large amounts of energy and they are hard on tooling. In addition, high noise levels.

Diğer presler yüksek enerji tüketirler ve parça işlemede serttirler. Ek olarak yüksek gürültü düzeyleri ve büyük bir yapı engellenemeyen hususlardandır



At our dkPOWER PRESSES, consisting of dkPOWER hydropneumatic cylinder has low energy&air consumption, fast approach stroke & they are easy on tooling.

dkPOWER hidropnömatik silindirlerini kullanarak yapılan dkPOWER presleri ise az hava ve enerji tüketirler, hızlı bir yaklaşma strokları vardır ve parça işlemede hassastırlar.

# C - FRAME PRESSES

# C tipi pres gövdesi

Our C frame presses is designed with dkPOWER hydropneumatic cylinders following accessories : standart , 2 column guided plate , 4 column guided plate.

C tipi pres gövdelerimiz, aşağıdaki özelliklere haiz olarak üretilirler: Standart, 2 Sütunlu dönmezlik parçası, 4 sütunlu dönmezlik parçası

Sample order : 15 ton C frame 4column guided press  
Sipariş örneği : 15 ton C pres- 4 sütunlu dönmezlik parçası

Press type : CP 15  
dkPOWER code : 06 S06-100-12  
The guide plate : SYC4-15  
The table type : M2-15  
Optional accessories :  
T-channels :  
Control type : Kumanda şekli

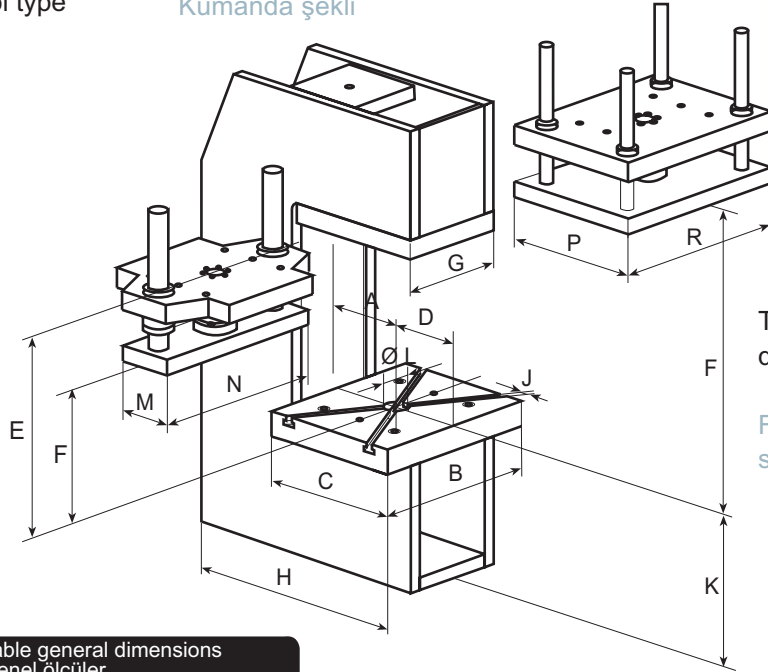

The different configurations and the specially developed accessories make it universally.

Farklı konfigürasyonlar ve özel aksesuarlar sistemin çok amaçlı kullanımına imkan verir

Table general dimensions  
Genel ölçüler

Measurements in mm / Ölçüler mm dir

Type Tip	Capacity Kapasite	A	B	C	D	E	F	G	H	I	JH11	K	Ø L	M	N	P	R
CP 01	1	100	250	180	90	285	200	140	350	60	10	150	30	185	244	185	244
CP 02	2	135	320	250	125	327	240	185	455	90	10	220	40	230	319	230	319
CP 04	4	150	320	280	140	361.5	260	185	540	105	10	250	50	245	319	245	319
CP 08	8	185	400	350	175	442	305	220	665	115	12	310	50	290	384	290	384
CP 15	15	220	450	400	200	473	335	270	785	155	12	360	50	365	434	365	434
CP 30	30	250	540	460	230	549	390	330	920	190	14	420	50	450	520	450	520
CP 50	50	270	620	500	250	602	420	350	1005	190	18	460	50	450	580	450	580
CP 75	75	270	920	500	250	692	465	500	1255	250		800	70			510	760
CP 100	100	270	980	500	250	692	465	550	1255	250		800	70			510	910

Note : Table dimensions are our standart program dimensions but you can contact with our company for your special needs.

Not : Tablolardaki ölçüler standart üretim programımıza göre düzenlenmiştir. Özel ihtiyaçlarınız için firmamız ile temasa geçiniz.

## 2 - COLUMN PRESSES

## 2 Sütunlu pres

Our 2 column presses is designed with dkPOWER hydropneumatic cylinders following accessories : standart , guided plate.

2 sütunlu preslerimiz,dkPOWER hidropnömatik silindirlere göre aşağıdaki özelliklerle dizayn edilmiştir : Standart, Ara plakalı.

Sample order : 2 ton - 2 column with guided plate  
Sipariş örneği : 2 ton 2 sütunlu – ara plakalı

Press type	Pres Tipi	: SP2 02
dkPOWER code	dkPOWER kodu	: 06 SK03 - 100 - 10
The guide plate	Ara plaka	: SY2 - 02
The table type	Masa tipi	: M1 - 02
Optional accessories	Opsiyonel özellikler	
T-channels	T-Kanal	
Fixing part	Sabitleme parçası	
Control type	Kumanda şekli	

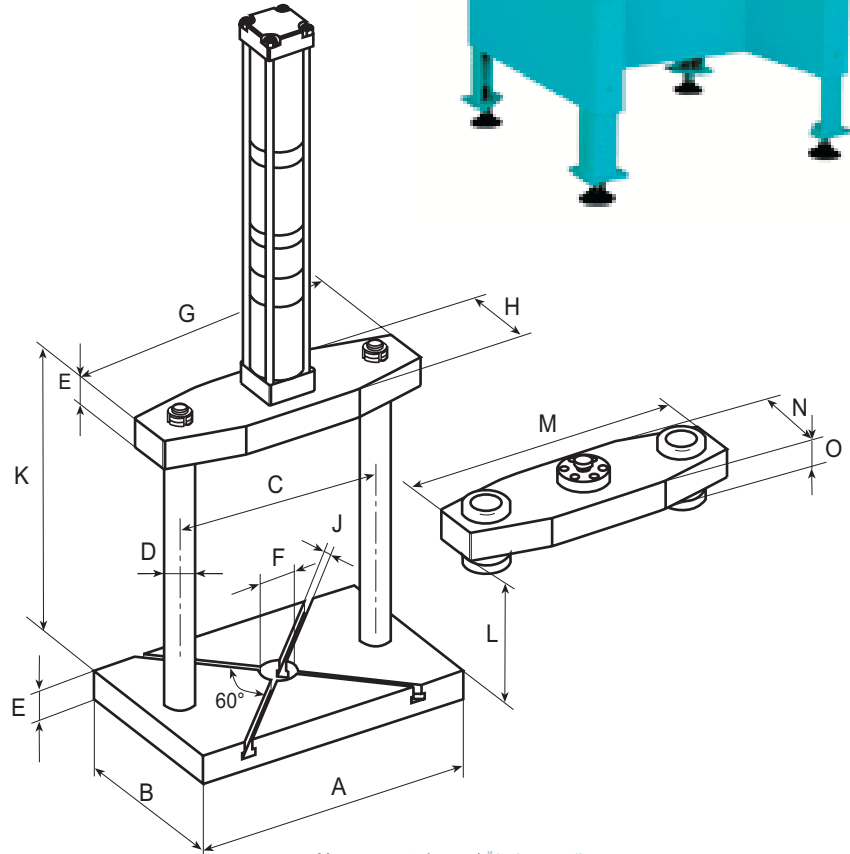

Table general dimensions  
Genel Ölçüler

Measurements in mm / Ölçüler mm dir

Type	Capacity	A	B	C	ØD	E	ØF	G	H	JH11	K	L	M	N	O
Tip	Kapasite														
SP2 01	1	400	240	280	30	29	40	398	110	10	390	238	392	104	28
SP2 02	2	400	260	280	40	39	40	398	130	10	380	236	392	124	28
SP2 04	4	400	300	280	40	39	50	398	130	10	420	252	392	124	28
SP2 08	8	460	350	300	50	49	50	458	160	10	450	225	452	154	38
SP2 15	15	460	350	300	50	59	50	458	160	12	480	245	452	154	48
SP2 30	30	500	350	300	63	69	60	498	230	12	490	224	492	224	48
SP2 50	50	500	350	300	80	89	60	498	280	12	550	241	492	274	58

## 4 - COLUMN PRESSES

## 4 Sütunlu pres

Our 4 column presses is designed with dkPOWER hydropneumatic cylinders following accessories : standart , guided plate.

4 sütunlu preslerimiz,dkPOWER hidropnömatik silindirlere göre aşağıdaki özelliklerle dizayn edilmiştir : Standart, Ara plakalı.

Sample order : 2 ton - 2 column with guided plate  
Sipariş örneği : 2 ton 4 sütunlu – ara plakalı.

Press type	Pres Tipi	: SP4 02
dkPOWER code	dkPOWER kodu	: 06 S03 - 100 - 06
The guide plate	Ara plaka	: SY4 - 02
The table type	Masa tipi	: M1 - 02
Optional accessories	Opsiyonel özellikler	
T-channels	T-Kanal	
Fixing part	Sabitleme parçası	
Control type	Kumanda şekli	

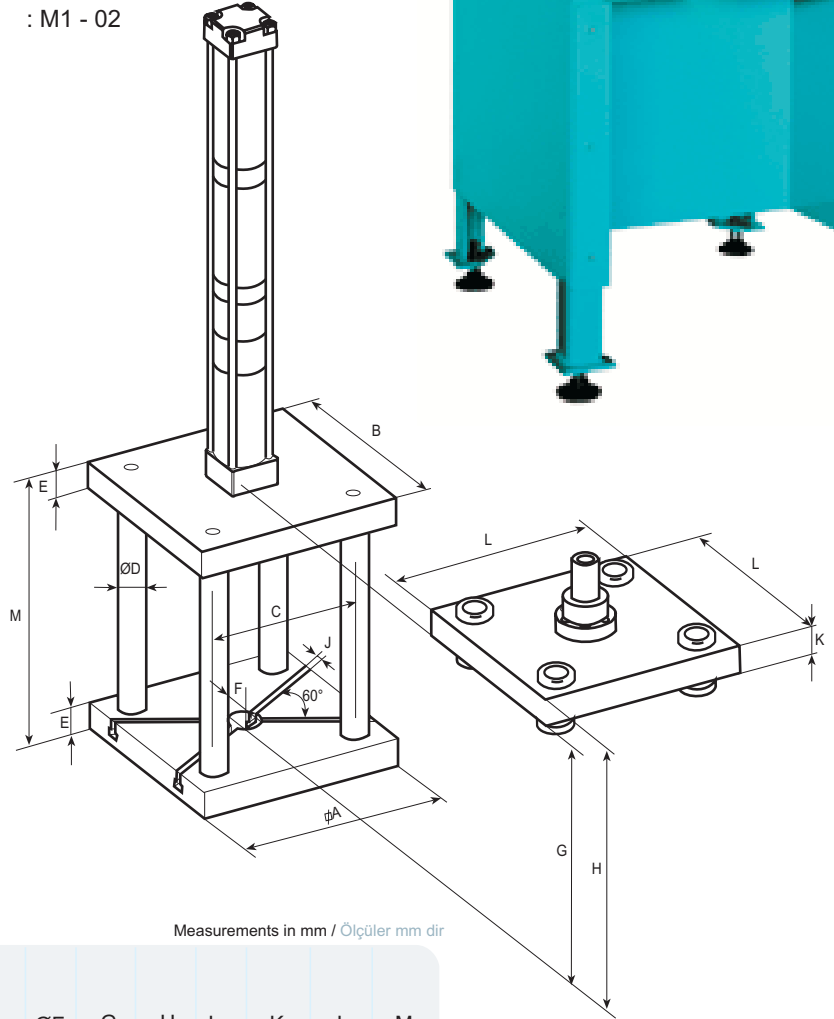

Table general dimensions  
Genel ölçüler

Measurements in mm / Ölçüler mm dir

Type	Capacity	A	B	C	ØD	E	ØF	G	H	JH11	K	L	M
Tip	Kapasite												
SP4 01	1	200	195	136	20	29	40	219	120	8	29	193	248
SP4 02	2	250	245	170	25	39	40	274	120	10	39	243	323
SP4 04	4	300	295	206	30	39	50	334	150	10	39	293	373
SP4 08	8	350	345	226	30	49	50	394	170	12	49	343	443
SP4 15	15	400	395	276	40	59	50	454	190	12	59	393	513
SP4 30	30	450	445	300	50	69	50	514	210	12	69	443	583
SP4 50	50	500	495	330	63	79	50	574	230	14	79	493	653

# THE PRESS TABLES

# Pres masaları

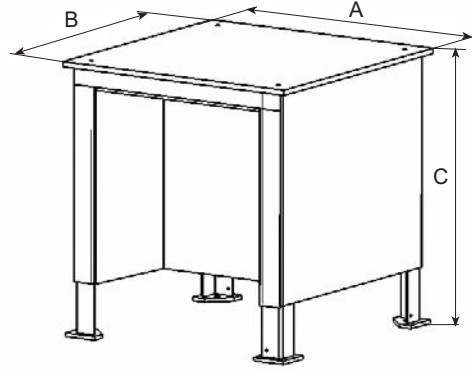

Table dimensions  
Tabla ölçüsü

Measurements in mm / Ölçüler mm dir

Type Tip	A	B	C
M1-01	600	600	750
M1-02	750	750	750
M1-04	750	750	750
M1-08	750	750	750
M1-15	750	750	750
M1-30	850	850	750
M1-50	850	850	750

The tables are designed for 2 column and 4 column presses.

Masalar 2 sütunlu ve 4 sütunlu presler için dizayn edilmiştir.

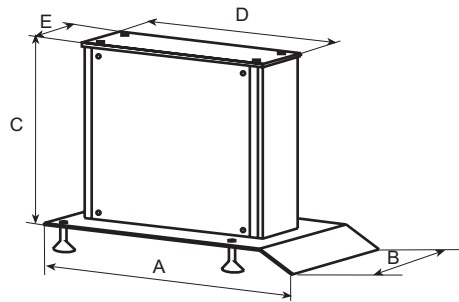
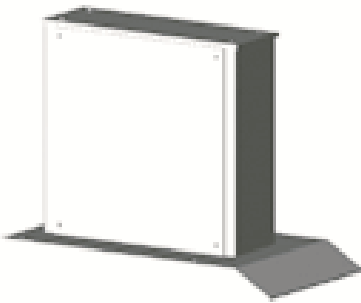

Table dimensions  
Tabla Ölçüsü

Measurements in mm / Ölçüler mm dir

Type Tip	A	B	C	D	E
M2 01	500	600	650	350	140
M2 02	600	600	580	455	185
M2 04	690	600	550	540	185
M2 08	815	700	490	685	220
M2 15	935	700	440	785	270
M2 30	915	700	380	920	330
M2 50	1000	700	340	1005	350

The foot is designed for C frame presses and the height between CP series with bottom plate is 800mm.

Pres ayakları C pres gövdeleri için dizayn edilmiş olup, yer ile pres gövdesi arası 800mm dir.



# ACCESSORIES

# Aksesuarlar

Fixing part (Please tighten with loctite) : Until 50 tons.  
Sabitleme parçası (Lütfen loctite ile sıkınız) : 50 ton'a kadar.

Tool holding fixture 01 Sabitleme parçası		Measurements in mm / Ölçüler mm dir									
Type	A	B	C	D	E	F	G	H	I	J	
AC 01 01	35	23	16	M12X1.5	16	15	28	46	5	7	
AC 02 01	35	23	16	M12X1.5	16	15	28	46	5	7	
AC 03 01	45	23	16	M16X1.5	20	15	28	46	5	7	
AC 04 01	65	33	26	M22X2	30	24	36	58	5	7	
AC 05 01	65	49	33	M30X2	45	29	54	82	8	10	
AC 06 01	75	49	33	M30X2	50	2	54	82	8	10	
AC 07 01	85	59	41	M39X2	56	9	56	88	10	12	
AC 08 01	95	75	52	M42X2	63	39	68	106	13	15	

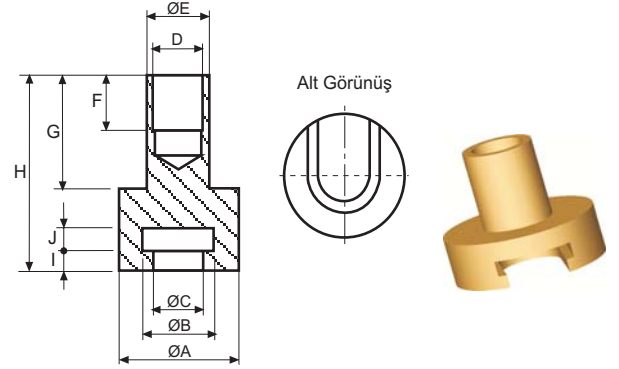

They are using with AC- -01 parts. Until 50 tons.  
AC- -01 parçaları ile beraber kullanılırlar. 50 ton'a kadar.

Tool holding fixture 02 Sabitleme parçası		Measurements in mm / Ölçüler mm dir							
Type	A	B	C	D	E	F	G	H	
AC 01 02	67	50	16	23	6.5	7	15	28	
AC 02 02	67	50	16	23	6.5	7	15	28	
AC 03 02	67	50	16	23	6.5	7	15	28	
AC 04 02	67	50	26	33	6.5	7	15	28	
AC 05 02	98	75	33	49	11	10	20	39	
AC 06 02	98	75	33	49	11	10	20	39	
AC 07 02	98	75	41	59	11	12	24	46	
AC 08 02	98	75	52	75	11	15	24	52	

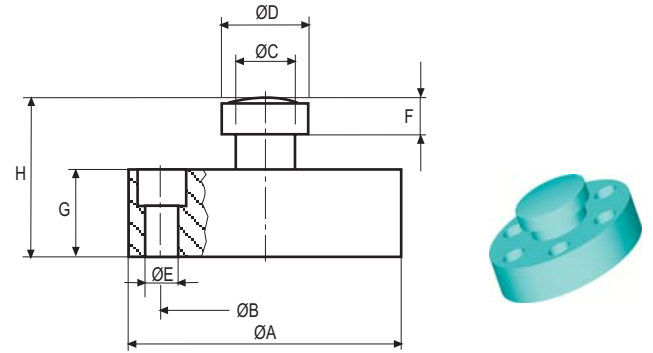

Anti-rotation fixture which has threads on the rod until 50 tons.  
Dönmezlik parçası 50 ton'a kadar kullanılır.

Tool holding fixture 03 Dönmezlik parçası		Measurements in mm / Ölçüler mm dir									
Type	A	B	C	D	E	F	G	H	I	J	
AC 01 03	35	20	32	M12X1.5	16	28	80	46	210	12	
AC 02 03	35	20	32	M12X1.5	16	28	80	46	210	12	
AC 03 03	45	20	32	M16X1.5	20	28	95	46	210	12	
AC 04 03	65	20	32	M22X2	30	36	112	58	225	16	
AC 05 03	65	40	50	M30X2	45	54	115	82	275	20	
AC 06 03	75	40	50	M30X2	50	54	132	82	275	20	
AC 07 03	85	40	50	M39X2	56	56	152	88	300	25	
AC 08 03	95	40	50	M42X2	63	68	160	106	325	25	

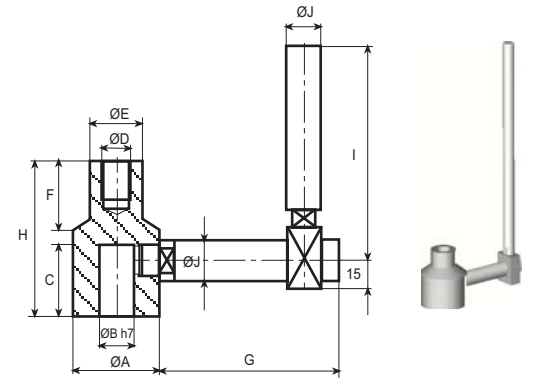

For your special assembly connection plate : For S-SK-PS type cylinders until 30 tons.  
Özel bağlantı parçası : S-SK-PS tipi silindirlere 30 ton'a kadar kullanılır.

Front mounting flange Onbağlantı flanşı		Measurements in mm / Ölçüler mm dir							
Type	A	B	C	D	E	F	G	H	
AF 01 00	88	55	30	19	3	6.5	40	75	
AF 02 00	88	62	30	19	3	6.5	40	75	
AF 03 00	124	75	40	24	3	9	54	105	
AF 04 00	144	85	50	24	4	9	64	125	
AF 05 00	175	112	70	29	4	11	88	156	
AF 06 00	220	136	75	29	5	17	100	195	
AF 07 00	270	170	100	36	5	21	132	255	

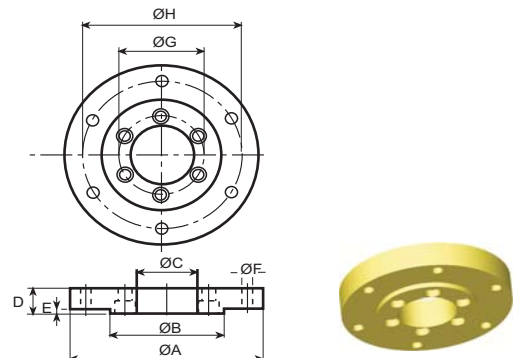



## Distributor

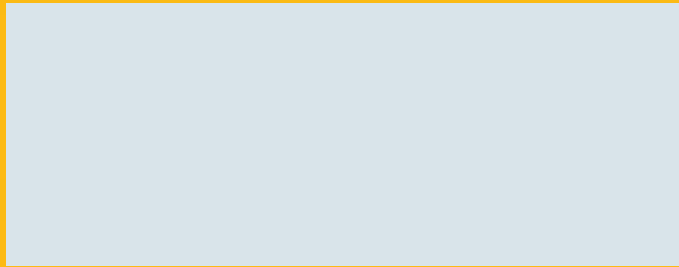

If you do not find a suitable type in our standard program, we are ready to build a special appliance according to your requirements.



### **DK OTOMASYON sistemler makina san. tic. ltd. Őti.**

Head office : Gazcılar cad. No:62/B 16220 Bursa • TURKEY

Tel : +90.224. 444 00 75

Fax : +90.224. 253 06 90

Factory : BeŐevler sanayi sitesi 34. blok No :71-92  
16149 Bursa • TURKEY

Tel : +90.224. 441 22 92

Fax : +90.224 441 22 93

[www.dk-power.com](http://www.dk-power.com) e-mail:[dk@dk-power.com](mailto:dk@dk-power.com)

Note : DK OTOMASYON reserves the right to carry out any modification to dimensions without prior notice.